



*BluePhase 1000*

**PHASE NOISE TEST SYSTEM**



**Operations Manual**

# Table of Contents

1.0	Introduction.....	3
1.1	Overview .....	3
1.2	Safety and Preparation for Use.....	3
1.3	Installation .....	3
1.4	Additional Equipment Requirements.....	4
1.5	Supply line and fuse.....	4
1.6	Connection to Other Instruments .....	4
1.7	Trademark and Copyright Information .....	4
1.8	Warranty.....	4
2.0	Features and Specifications .....	5
2.1	Key Features.....	5
2.2	Specifications .....	5
3.0	Operation <i>BP-1000-SC</i> – Single Channel Configuration.....	6
3.1	Front Panel Overview.....	6
3.2	Rear Panel Overview .....	6
3.3	Initial Power On.....	6
3.4	Calibration .....	6
3.5	Measuring Phase Noise on Single Channel Model: <i>BP-1000-SC</i> .....	7
4.0	Operation <i>BP-1000-CC</i> – Cross-Correlation Configuration.....	11
4.1	Front Panel Overview.....	11
4.2	Rear Panel Overview .....	11
4.3	Initial Power On.....	11
4.4	Calibration .....	11
4.5	Measuring Phase Noise – Cross Correlation Model: <i>BP-1000-CC</i> .....	12
4.6	Single Channel Absolute Phase Noise Measurement.....	15
5.0	Operation <i>BPMS-1000-RM</i> – Residual Measurement Configuration .....	17
5.1	Front Panel Overview.....	17
5.2	Rear Panel Overview .....	17
5.3	Initial Power On.....	17
5.4	Calibration .....	17
5.5	Measuring Residual Phase Noise.....	18
6.0	Base Module Descriptions.....	24
6.1	Mixer/LPF – <i>BPMX-1000</i> .....	24
6.2	Phase Lock Control – <i>BPPLL-1000</i> .....	24
6.3	Audio Amplifier – <i>BPAA-1000</i> .....	24
6.4	Meter – <i>BPM-1000</i> .....	25
6.5	Speaker – <i>BPS-1000</i> .....	25
6.6	Variable Voltage – <i>BPVV-1000</i> .....	25
6.7	USB Controller – <i>BPUSB-1000</i> .....	26
7.0	Standard Configurations.....	28
7.1	<i>BP-1000-SC</i> – Single Channel Absolute Measurement System.....	28
7.2	<i>BP-1000-CC</i> – Cross-Correlation Absolute Measurement System.....	28
7.3	<i>BP-1000-RM</i> – Residual Measurement System.....	28
8.0	Additional Modules - <i>BluePhase 1000</i> .....	29
9.0	Rear Panel Connections.....	30
10.0	Correction Factor Table .....	30



**WENZEL ASSOCIATES, INC.**

**BLUEPHASE 1000** v1.01

PRINTED IN USA MAY 2007

## 1.0 INTRODUCTION

### 1.1 OVERVIEW

Wenzel Associates' **BLUEPHASE 1000™** series test sets integrate **BLUE TOPS™** and other ultra low noise components into a manually operated or computer controlled phase noise measurement system. **BLUEPHASE 1000** test sets are constructed to allow complete flexibility in modular configurations while achieving exceptionally low noise floors.

The **BluePhase 1000** phase noise test systems are housed in a two chassis configuration: the **BPMS-1000** Phase Noise Measurement System and the **BPPS-1000** Low Noise Power Supply. The measurement system is housed in a 5¼" high rack mountable chassis and the low noise power supply, housed in a 5¼" half-rack chassis (full-rack available). These systems are configured to facilitate accurate phase noise measurements of RF and microwave sources utilizing a two-source approach.

The **BluePhase 1000** can be configured with a selection of modules to construct the desired test instrument. Each module may be independently replaced to facilitate the test. Additional modules are available to increase the versatility of the test set for broader applications. Please see the Appendix for more information.

Capabilities of any basic configuration (*See Appendix for more information*) may be extended or enhanced by adding, exchanging, or simply removing modules. Noise floors to  $\leq -190$  dBc (cross correlation) may be obtained. Input frequencies can be increased and measurement offsets extended to 20 MHz. Built in or external reference sources can be accommodated. The instrument may be used for Residual Phase noise measurement, and, with addition of optional regulators, clean auxiliary power may be made available.

### 1.2 SAFETY AND PREPARATION FOR USE

**WARNING!** DANGEROUS VOLTAGES, CAPABLE OF CAUSING DEATH, ARE PRESENT IN THIS INSTRUMENT. SERVICE ON THIS INSTRUMENT SHOULD BE PERFORMED ONLY BY QUALIFIED PERSONS WHO ARE AWARE OF THE POTENTIAL HAZARDS OF WORKING WITH ELECTRICAL CIRCUITS WHEN THE INSTRUMENT COVERS ARE REMOVED.

An uninterruptible safety earth ground must be provided from the main power source to the power supply input wiring terminals, power cord, and/or supplied power cord set.

Any interruption of the protective grounding (inside or outside the power supply) or disconnection of the earth ground terminal will cause a potential shock hazard that could result in personal injury. Verify that a common ground exists between this unit and all other devices connected to or in proximity to this unit prior to energizing any of the instruments.

If this instrument is to be powered via an auto transformer (for voltage reduction), ensure that the common terminal is connected to neutral (grounded side of the mains supply).

Capacitors inside this instrument may still be charged even if the instrument has been disconnected from its power source.

### 1.3 INSTALLATION

#### Contents

The following components are Included with the Phase Noise Test Set:

- **BLUEPHASE 1000** Phase Noise Measurement System  
(For configurations available, see the Appendix)
- **BLUEPHASE 1000** Power Supply, Model **BPPS-1000**
- AC Power Cord
- DC Supply Interconnect Cable
- RF Cables, with SMA connectors
- BNC (M) / MINIGRABBER Cable, Model 5187-K-36
- MCC Model PMD-1208FS User's Guide
- MCC Data Acquisition Software and Documentation
- USB Cable
- Ulinx USB Extender – Isolator, Model UEF10M
- Ulinx Model UEF10M User's Guide

#### 1.4 ADDITIONAL EQUIPMENT REQUIREMENTS

- Oscilloscope
- FFT Analyzer (for offsets to 100 kHz) Recommend: SR760
- Spectrum Analyzer (for offsets to 20 MHz)
- Optional computer with a USB communications port running Microsoft Windows (XP recommended)

#### 1.5 SUPPLY LINE AND FUSE

The **BPMS-1000** Phase Noise Measurement System is designed for connection to DC voltages (detailed in Section 2.2.) DC is supplied by the included power supply via a 9 pin d-subminiature connector on the rear panel using the provided cable. Damage to the instrument may result if other supplies are utilized.

The **BPPS-1000** power supply is designed for connection to an AC supply as specified in Section 2.2 with the included power cord. Damage to the instrument may result if other supplies are utilized. For continued protection against fire hazard, replace the AC supply line fuses only with fuses rated as specified.

#### 1.6 CONNECTION TO OTHER INSTRUMENTS

Connector shields are connected to the chassis ground and to safety earth ground via the DC return and power supply ground connections. Do not apply any voltage to the chassis or connector shields. The connector shields are not protected against connection to any potential other than DC ground.

#### 1.7 TRADEMARK AND COPYRIGHT INFORMATION

- **BluePhase, BluePhase 1000**, and **BlueTops** are trademarks of Wenzel Associates, Inc.
- Personal Measurement Devices brand and Measurement Computing Corporation are trademarks or registered trademarks of Measurement Computing Corporation.
- Microsoft and Windows are trademarks or registered trademarks of Microsoft Corporation.
- LabVIEW is a trademark or registered trademark of National Instruments.
- Ulinx is a trademark or registered trademark of B & B Electronics Manufacturing Company.
- MINIGRABBER is a trademark or registered trademark of Pomona Electronics.
- All other trademarks are the property of their respective owners.

#### 1.8 WARRANTY

All products manufactured and sold by Wenzel Associates, Inc. are warranted to be free of defects under normal operating conditions, as specified, for one year from date of original shipment from Wenzel Associates, Inc. This warranty is in lieu of all other warranties, expressed or implied. Wenzel Associates, Inc. is not liable for loss or damage incurred by the customer in connection with the purchase or use of the product. Products that have been repaired or modified by non-authorized persons are not covered by this warranty.

***WARNING: DO NOT HOT SWAP  
Serious Damage May Result – Turn Unit Off to Change Modules.  
Failure to do so will void your warranty.***

## 2.0 FEATURES AND SPECIFICATIONS

### 2.1 KEY FEATURES

- Measures frequencies up to 1.5 GHz
- Measures noise floors to  $\leq -178$  dBc,  $\leq -190$  dBc for Cross Correlation.
- Measures offsets to 100 kHz
- Multi-function analog panel meter
- Speaker for noise monitoring and troubleshooting
- Variable voltage source for auxiliary electrical tuning
- USB port interface allows computer control of the instrument

### 2.2 SPECIFICATIONS

<b>BLUEPHASE 1000 PHASE NOISE MEASUREMENT SYSTEM</b>	
<b>SSB PHASE NOISE</b>	$\leq -178$ dBc/Hz at 10 kHz (Typical for Single Channel and Residual Measurement System) $\leq -190$ dBc at 10 MHz for Cross Correlation.
<b>FREQUENCY RANGE</b>	5 MHz to 1.5 GHz [extended range available]
<b>OFFSET ANALYSIS</b>	1 Hz to 100 kHz (input frequency and tuning sensitivity dependent) [to 20 MHz available]
<b>MEASUREMENT ACCURACY</b>	$\pm 1.5$ dB (<100 kHz offset) [ $\pm 2$ dB (<20 MHz offset) optional]
<b>INPUT SIGNAL LEVEL</b>	+14 dBm into 50 ohms
<b>INPUT / OUTPUT CONNECTORS</b>	SMA female, BNC female
<b>ELECTRICAL TUNING OUTPUT TO VCO</b>	$\pm 14$ VDC
<b>SPURIOUS</b>	$< -110$ dBc
<b>SUPPLY VOLTAGE</b>	$+18^{-0.5}/_{+1}$ VDC $-18^{-1}/_{+0.5}$ VDC
<b>SUPPLY VOLTAGE CONNECTOR</b>	D-subminiature 9 pin connector
<b>POWER CONSUMPTION</b>	$< 500$ mA @ $\pm 18$ VDC $\pm 5\%$ , standard
<b>MINIMUM/MAXIMUM OPERATING TEMPERATURE RANGE</b>	0 to $+50^{\circ}\text{C}$
<b>NORMAL OPERATING TEMPERATURE (LABORATORY)</b>	20 to $30^{\circ}\text{C}$
<b>DIMENSIONS (W X D X H)</b>	$17\frac{7}{8} \times 15 \times 5\frac{1}{4}$ " (3U) [19" rack mountable]

<b>BPPS-1000 BLUEPHASE POWER SUPPLY</b>	
<b>SUPPLY VOLTAGE</b>	115/230 VAC, 50/60 Hz [selectable]
<b>OUTPUT VOLTAGE</b>	$+18^{-0.5}/_{+1}$ VDC, 1.5A $-18^{-1}/_{+0.5}$ VDC, 1.5A
<b>SUPPLY VOLTAGE CONNECTOR</b>	D-subminiature 9 pin connector
<b>MINIMUM/MAXIMUM OPERATING TEMPERATURE RANGE</b>	0 to $+50^{\circ}\text{C}$
<b>NORMAL OPERATING TEMPERATURE (LABORATORY)</b>	20 to $30^{\circ}\text{C}$
<b>SUPPLY FUSE</b>	AC: 250V, 1.5 A, slow blow. DC: 250V, 3A, slow blow (internal)
<b>DIMENSIONS (W X D X H)</b>	$9\frac{1}{4} \times 11\frac{1}{8} \times 5\frac{1}{4}$ " (3U) (half-rack standard, full-rack available)

**WARNING: DO NOT HOT SWAP**  
**Serious Damage May Result – Turn Unit Off to Change Modules.**  
**Failure to do so will void your warranty.**

**READ SECTIONS 1.2 AND 1.3 PRIOR TO OPERATION OF THIS INSTRUMENT.**

### 3.0 OPERATION **BP-1000-SC** – SINGLE CHANNEL CONFIGURATION

The **BP-1000-SC** Single Channel Absolute Phase Noise Test Set consists of a two chassis configuration. The **BPMS-1000-SC** is the Absolute Phase Noise instrument. This unit is powered by the **BPPS-1000** Low Noise Power Supply. The **BPMS-1000-SC** phase noise measurement system is configured to facilitate accurate single sideband (SSB) absolute phase noise measurements of RF and microwave sources utilizing a two-source approach.

The single channel phase noise measurement technique for a frequency source compares the phase of the device under test (DUT) to a reference frequency source (REF) with similar or superior noise performance. The relative phase of the two frequency sources is held at quadrature so that small phase variations convert into voltage variations at the output of the MIXER/LPF. Although the PHASE LOCK CONTROL is constantly working to eliminate these phase variations, when possible, the time constant is set long enough to preserve the slowest phase variations of interest. The power spectral density of the output audio noise of the circuit can be measured with a signal analyzer and is easily converted to phase noise by correcting for mixer conversion and amplifier gain.

#### 3.1 FRONT PANEL OVERVIEW

The **BPMS-1000-SC** single channel instrument is comprised of a mixer with low pass filters (MIXER/LPF), PHASE LOCK CONTROL, AUDIO AMPLIFIER, METER, SPEAKER, VARIABLE VOLTAGE source, and USB controller. All test connections are made at the front panel



Figure 3.1-1

#### 3.2 REAR PANEL OVERVIEW

##### **BPMS-1000-SC**

The DC supply DB9 input connector (Appendix III, Table I) and power switch are located on the rear panel. All other connections used during normal operation of the unit are on the front panel.

##### **BPPS-1000**

The AC supply power entry (Appendix III, Table II) is located on the rear panel of the **BPPS-1000**. The power entry module may be configured for 115 or 230 VAC supply. The setting is indicated in the window on the module. The DC supply output D-subminiature connector (Appendix III, Table I) located on the rear panel of the unit connects to the DC supply input D-subminiature connector with the supplied cable.

#### 3.3 INITIAL POWER ON

Connect the supplied DC supply interconnect cable to the **BPPS-1000** power supply and **BPMS-1000-SC** instrument via the 9 pin D-subminiature connectors on the rear panels. Connect the supplied power cord to the **BPPS-1000** power supply at the power entry module and to an appropriate AC voltage source. Switch the power on to both units.

**Note:** Switch the power off to the phase noise measurement system or the **BPPS-1000** power supply while configuring the test set.

#### 3.4 CALIBRATION

Annual factory calibration of the AUDIO AMPLIFIER module(s) is recommended.

No periodic calibration of the remainder of the phase noise measurement system is required.

No field calibration of the **BPPS-1000** power supply is required.

### 3.5 MEASURING PHASE NOISE ON SINGLE CHANNEL MODEL: *BP-1000-SC*



Figure:3.5 -1

#### 3.5.1 SINGLE CHANNEL PHASE NOISE MEASUREMENT TECHNIQUE

The single channel phase noise measurement technique for a frequency source determines the combined absolute phase noise of the device under test (DUT) and a reference frequency source (REF) with similar or superior noise performance. The PHASE LOCK CONTROL holds the relative phase of the two frequency sources at quadrature so that small phase variations convert into voltage variations at the output of the MIXER/LPF. Although the PHASE LOCK CONTROL is constantly working to eliminate these phase variations, when possible, the time constant is set long enough to preserve the slowest phase variations of interest. The MIXER/LPF module incorporates a low pass filter to block the RF frequencies to the AUDIO AMPLIFIER and PHASE LOCK CONTROL. The power spectral density of the output audio noise of the circuit can be measured with a signal analyzer and is easily converted to phase noise by correcting for mixer conversion and amplifier gain.

The phase slope of the MIXER/LPF may be determined in a number of ways including the observation of a beat-note on the oscilloscope or applying a known frequency modulation to the reference frequency source.

The noise output from the MIXER/LPF can be quite low, requiring amplification before signal analysis. The AUDIO AMPLIFIER exhibits intrinsic noise below 1nV/root-Hz and the MIXER/LPF exhibits similar performance with phase slopes near 1 volt/radian. Figure 3.5.2-1 below depicts a block diagram for the single channel absolute phase noise measurement configuration.

#### 3.5.2 INITIAL CONNECTIONS

Set up of the instrument is simple. Plug the power supply (*BPPS-1000*) into the back of the *BP-1000-SC*. Once that is secure, turn the units on, and if rack mounted, place in the rack. There are no other connections or functions to be performed at the rear panels. All connections are made at the front of the instrument. Some of the connections indicated in the block diagram are internal and are so marked. To initially set up the *BP-1000-SC* unit for absolute phase noise measurements, make the following front panel connections:

1. Locate the MIXER/LPF and on it the two SMA connectors labeled "OUT". Using the small coaxial cables provided, connect one to the "PLL IN" on the Phase Lock module and the other to the "INPUT HIGH Z" connector on the Audio Amplifier. (These units are factory installed on either side of the MIXER/LPF.)
2. Connecting the Reference Source next, attach appropriate cable from the "ET OUT" on the Phase Lock Module to the tuning input of the Reference. Then connect the RF output of the Reference to the "LO IN" of the MIXER/LPF.
3. Connect "OUTPUT LOW Z" to the input ports on an FFT analyzer and Oscilloscope.
4. Finally, connect the RF output from the Device Under Test (DUT) to the "RF IN" of the MIXER/LPF.

Bring everything up and begin testing. Check the setup with the Figure 3.5.2-1.



### 3.5.3 SINGLE CHANNEL TWO SOURCE PHASE NOISE MEASUREMENT

Measuring the absolute phase noise of a frequency source is a relatively straightforward 4 step process:

1. measure the mixer slope,
2. lock the frequency sources,
3. measure the PSD using an FFT, and
4. calculate the phase noise.

#### 3.5.3.1 STEP 1: MEASURING MIXER SLOPE

1. Set the AUDIO AMPLIFIER gain switch to the 0 dB position.
2. Set the PHASE LOCK CONTROL ET switch to the VAR ET position. To monitor the VAR ET voltage, switch the METER input to the PLL position.
3. On the oscilloscope, set the trigger to normal and DC couple the vertical input.
4. Adjust the VAR ET such that exactly one period ( $2\pi$  radians) of the beat note is displayed on the screen (10 divisions) with the beat note at a relatively low frequency. See Figure 3.5.3.1-1. To monitor the audible beat note, switch the SPEAKER to the PLL position and adjust the VOLUME to desired level.
5. Adjust the oscilloscope time base to expand the view of the waveform to 1/100th that in the original view. (e.g. – change from  $T_1 = 10$  msec / div to  $T_2 = 0.1$  msec / div. This is a convenient change of 6 positions on a 1, 2, 5 oscilloscope).  
 $R = [(T_2 \times 10) / (T_1 \times 10)] \times 2\pi \text{ radians} = (1 \text{ msec} / 100 \text{ msec}) \times 2\pi \text{ radians} = 0.02\pi \text{ radians}$
6. The displayed portion of the waveform is now  $0.02\pi$  radians. See Figure 3.5.3.1-2.
7. Adjust the oscilloscope vertical scale and trigger level (do not adjust the vertical position) to view the partial waveform vertically within the screen at the left and right of the screen (10 divisions). See Figure 3.5.3.1-3. Measure the voltage change for this portion of the waveform ( $\Delta V = \# \text{ of divisions} \times V / \text{division}$ ) and calculate the slope in volts / radian using the following equation: Slope =  $\Delta V / R = \Delta V / 0.02\pi \text{ radians}$

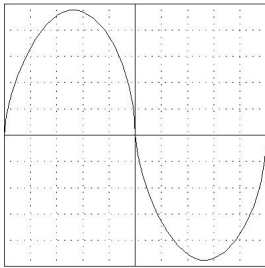

**Figure 3.5.3.1-1**  
One period beat note (10 to 100 Hz)

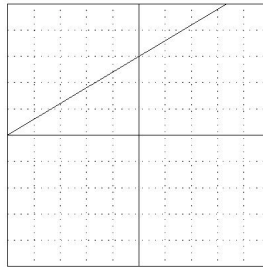

**Figure 3.5.3.1-2**  
 $0.02\pi$  radians beat note

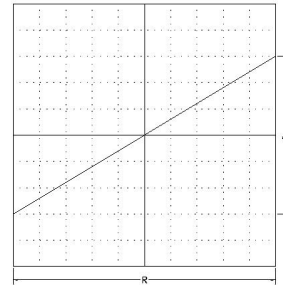

**Figure 3.5.3.1-3**  
 $0.02\pi$  radians vertically adjusted

#### 3.5.3.2 STEP 2: LOCK THE FREQUENCY SOURCES

1. Set the PHASE LOCK CONTROL ET switch to the PLL ET GAIN position. To monitor the PLL ET voltage, switch the METER input to PLL position.
2. Note: The LOCK LED will be ON if one or both of the RF inputs are not present as there will be no beat note.
3. Use the PHASE LOCK CONTROL SLEW momentary switch to aid acquisition. The beat note will slow until it reaches a flat DC level as the REF frequency approaches the DUT frequency.
4. Set the AUDIO AMPLIFIER gain switch to the 30/60 dB position and the amplifier switch to the desired position (DC, AC1, etc). See note at paragraph 3.5.3.3.
5. Adjust the oscilloscope trigger to auto and the time base and vertical scale (AC coupled) to settings convenient for viewing the audio noise waveform.
6. To monitor the audible noise of the circuit, switch the SPEAKER to the PLL position and adjust the VOLUME to desired level.

### 3.5.3.3 STEP 3: MEASURE THE PSD USING THE FFT

1. On the FFT analyzer, set the vertical scale to PSD in units of  $\text{dBV}_{\text{RMS}} / \sqrt{\text{Hz}}$  and frequency scale to include the desired frequency offset to be measured.
2. Measure the PSD.

Note that even with 60 dB gain, the input setting of the FFT analyzer must be adjusted low enough to view the amplified noise. Low frequency noise that may overload the amplifier of FFT analyzer may be rolled off using the high pass filters built into the AUDIO AMPLIFIER. The high pass filter must be flat at the offset frequency to be measured. (Setting AC1 is flat above 10 Hz, AC2 is flat above 100 Hz, and AC3 is flat above 1000 Hz).

### 3.5.3.4 STEP 4: CALCULATE THE ABSOLUTE PHASE NOISE.

The combined phase noise of the DUT and REF is determined by applying the appropriate adjustments to the measured PSD. This is accomplished by using the equation:

$$L(f)_{\text{COMB}} = [\text{PSD}] - [20\log(\text{slope})] - [\text{amp gain}] - [\text{correction for SSB measurement}]$$

e.g.– for a circuit with the slope determined as 0.75 V / radian, the AUDIO AMPLIFIER amp select switch to **AC1**, and the PSD at 1000 Hz is measured as  $-96 \text{ dBV}_{\text{RMS}}/\sqrt{\text{Hz}}$ , the phase noise is calculated as

$$\begin{aligned} L(1000)_{\text{COMB}} &= -96 - 20\log(0.75) - 60 - 3 \\ &= -96 - (-2.5) - 60 - 3 \\ &= -156.5 \text{ dBc/Hz} \end{aligned}$$

To determine the noise of the DUT, the noise of a known reference source may be backed out using the following equation:

$$L(f)_{\text{DUT}} = 10\log [10^{L(f)_{\text{COMB}}/10} - 10^{L(f)_{\text{REF}}/10}]$$

1. This correction is significant when the phase noise of the reference source is within 10 dB of the **DUT**.
2. e.g. –using the results from above, and assuming the phase noise of the reference source is known to be  $-162 \text{ dBc/Hz}$  at 1000 Hz offset, the phase noise of the DUT is calculated as

$$\begin{aligned} L(1000)_{\text{DUT}} &= 10\log [10^{(-156.5/10)} - 10^{(-162/10)}] \\ &= 10\log [10^{-15.65} - 10^{-16.2}] \\ &= 10\log [2.239 \cdot 10^{-16} - 0.631 \cdot 10^{-16}] \\ &= 10\log [1.608 \cdot 10^{-16}] \\ &= 10 [-15.79] \\ &= -157.9 \text{ dBc/Hz} \end{aligned}$$

3. By applying the appropriate correction factor based on this equation from Table III, a quick result can be obtained. With a known  $L(f)_{\text{REF}}$  and the combined phase noise measured  $L(f)_{\text{COMB}}$ , the difference is calculated. The associated correction factor from Table III is subtracted from the combined phase noise measured to obtain the corrected phase noise.

e.g. –  $L(f)_{\text{COMB}} - L(f)_{\text{REF}}$

i.  $= -162 \text{ dBc/Hz} - -156.5 \text{ dBc/Hz}$

ii.  $= -5.5 \text{ dB}$

rounding to  $-6 \text{ dB}$  the CF is determined to be  $-1.3 \text{ dB}$

$$L(f)_{\text{DUT}} = -156.5 \text{ dBc/Hz} - 1.3 \text{ dB}$$

iii.  $= -157.8 \text{ dBc/Hz}$

## 4.0 OPERATION **BP-1000-CC**— CROSS-CORRELATION CONFIGURATION

The **BP-1000-CC** Cross-Correlation Absolute Phase Noise Test Set consists of a two chassis configuration. The **BPMS-1000-CC** Cross-Correlation Phase Noise Measurement instrument and it is powered by the **BPPS-1000** Low Noise Power Supply. The **BPMS-1000-CC** is configured to facilitate accurate single sideband (**SSB**) absolute phase noise measurements of RF and microwave sources utilizing a three-source approach.

The cross-correlation phase noise measurement technique requires two reference sources (REF) and one device under test (DUT) source. The DUT signal is fed through a high isolation reactive power splitter and then into each of two nearly identical phase-locked loops. The two references are locked and held at quadrature to the DUT. The phase deviations of these two signals are amplified and analyzed simultaneously using a dual channel FFT. The incoherent noise contributions of both channels are averaged away leaving only the common noise of the DUT. The result is a 15 to 20 dB improvement compared to the single channel two-source approach.

### 4.1 FRONT PANEL OVERVIEW

The **BPMS-1000-CC** cross correlation instrument is comprised of two mixers with low pass filters (2 MIXERS/LPFS), 2 PHASE LOCK CONTROLS, 2 AUDIO AMPLIFIERS, METER, SPEAKER, VARIABLE VOLTAGE source, and USB controller.



Figure 4.1-1

### 4.2 REAR PANEL OVERVIEW

#### **BPMS-1000-CC**

The DC supply input DB9 connector (Appendix III, Table I) and power switch are located on the rear panel of the instrument. . All other connections used during normal operation of the unit are on the front panel.

#### **BPPS-1000**

The AC supply power entry (Appendix III, Table II) is located on the rear panel of the **BPPS-1000**. The power entry module may be configured for 115 or 230 VAC supply. The setting is indicated in the window on the module. The DC supply output D-subminiature connector (Appendix III, Table I) located on the rear panel of the unit connects to the DC supply input D-subminiature connector with the supplied cable.

### 4.3 INITIAL POWER ON

Connect the supplied DC supply interconnect cable to the **BPPS-1000** power supply and the phase noise measurement system via the 9 pin D-subminiature connectors on the rear panels. Connect the supplied power cord to the **BPPS-1000** power supply at the power entry module and to the appropriate AC voltage source. Switch the power on to both units.

**Note:** Switch the power off to the phase noise measurement system or the **BPPS-1000** power supply while configuring the test set.

### 4.4 CALIBRATION

Annual factory calibration of the AUDIO AMPLIFIER module(s) is recommended.

No periodic calibration of the remainder of the phase noise measurement system is required.

No field calibration of the **BPPS-1000** power supply is required.

## 4.5 MEASURING PHASE NOISE – CROSS CORRELATION MODEL: *BP-1000-CC*



Figure 4.5-1

### 4.5.1 CROSS-CORRELATION MEASUREMENT TECHNIQUE

Figure 4.5.2-2 below depicts a block diagram for the cross-correlation absolute phase noise measurement configuration. Cross-correlation phase noise measurement for a frequency source determines the absolute phase noise of the device under test (DUT) when compared to two reference frequency sources with similar or superior noise performance. The DUT signal is fed through a high isolation reactive power splitter and into two MIXER/LPF modules, which incorporate low pass filters to block the RF frequencies to the AUDIO AMPLIFIER and PHASE LOCK CONTROL modules. The PHASE LOCK CONTROL modules hold the relative phase of the two reference frequency sources at quadrature with the DUT so that small phase variations are converted into voltage variations at the output of the MIXER/LPF modules. Although the PHASE LOCK CONTROL modules are constantly working to eliminate these phase variations, when possible, the time constant is set long enough to preserve the slowest phase variations of interest. The phase variations are then amplified and analyzed simultaneously using a dual channel FFT analyzer. The incoherent noise contributions of both channels are averaged away leaving only the common noise to the DUT. The result is a 15 to 20 dB improvement compared to the single channel, two-source phase noise measurement.

The noise output from the MIXER/LPF can be quite low, requiring amplification before signal analysis. The AUDIO AMPLIFIER modules exhibit intrinsic noise below 1nV/root-Hz and the MIXER/LPF modules exhibit similar performance with phase slopes near 1 volt/radian. The phase slope of the MIXER/LPF modules may be determined in a number of ways including the observation of a beat-note on the oscilloscope or applying a known frequency modulation to the reference frequency source.

### 4.5.2 INITIAL CONNECTIONS [CROSS-CORRELATION]

Set up of the instrument is simple. Plug the *BPPS-1000* power supply into the back of the *BP-1000-CC*. Once that is secure, turn the units on, and if rack mounted, place in the rack. There are no other connections or functions to be performed at the rear panels. All connections are made at the front of the instrument. Some of the connections indicated in the block diagram are internal and are so marked.

With the cross correlation configuration, notice that there are two sets of modules that were also described on the single channel instrument. They are the Audio Amplifiers (AMP), the Mixer/LPFs, and the Phase Lock Controls (PLL). They are operated as sets, each measuring one of two channels. To initially set up the *BP-1000-CC* unit make the following front panel connections:

1. Locate the two mixers. They are factory installed between their associated AMP and PLL. On each one there are two output SMAs marked "OUT." It does not matter which of the two "OUTs" are selected but the upper one is most easily connected to the AMP via the connector marked "INPUT HIGH Z." The lower two "OUTs" may then be connected to the adjacent PLL via the connectors marked "PLL IN." These connections need not be removed.

2. Cross correlation uses two reference sources, one for each channel. Connect the RF output of each to each mixer SMA marked "LO IN." Complete the reference connection by taking the "ET OUT" of the corresponding PLL (channel #1 or #2) and connecting it to the ET input of the reference.
3. On each of the AMPs, locate the "OUTPUT LOW Z" SMA connectors. Connect the coaxial cable to the channel one and two ports of your FFT Analyzer and Oscilloscope.
4. Finally, connect the output of the device to be tested to a splitter, the two outputs of which are connected to the mixer SMAs marked "RF IN."

**WARNING: DO NOT HOT SWAP**  
**Serious Damage May Result – Turn Unit Off to Change Modules.**  
*Failure to do so will void your warranty.*

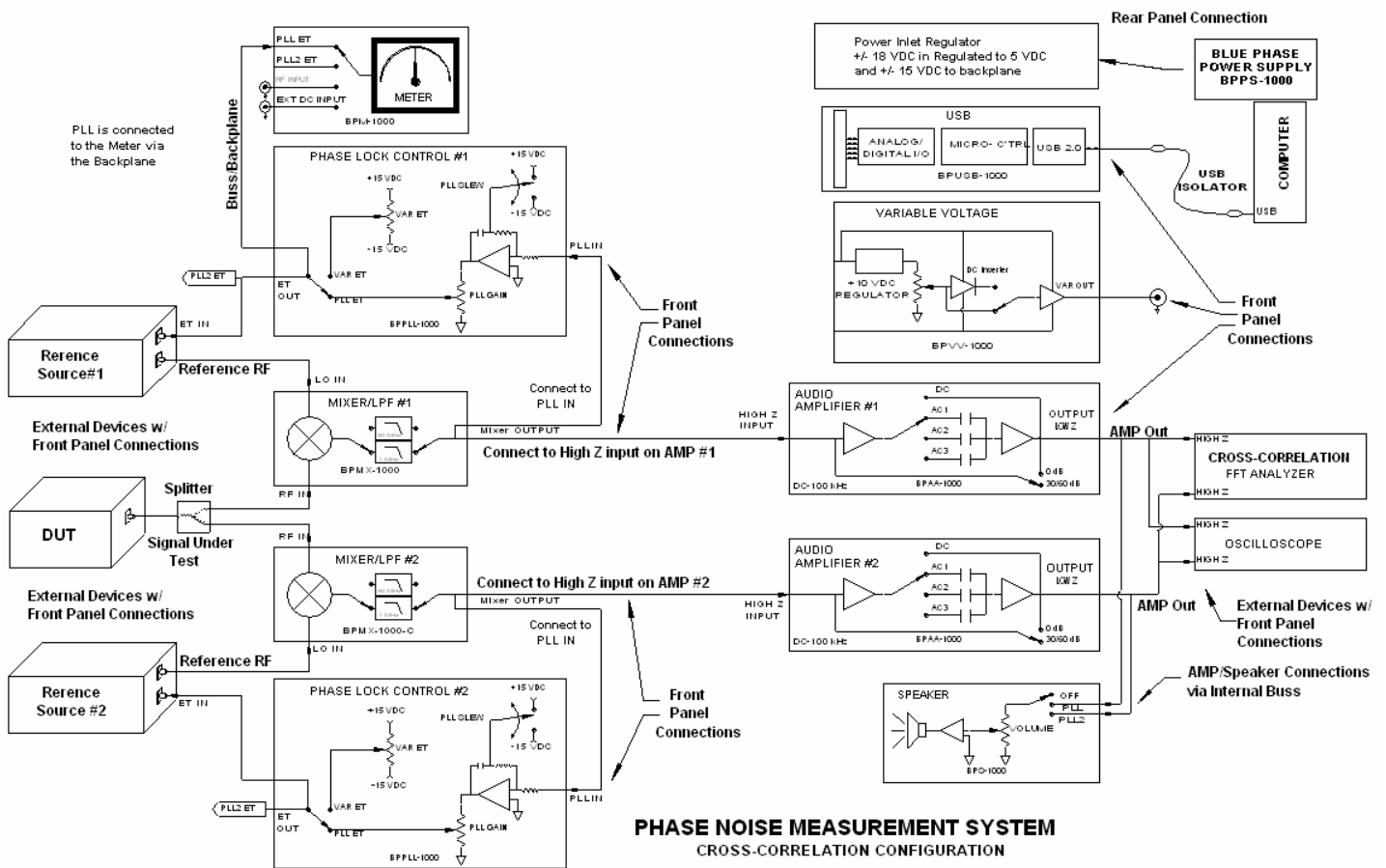

**Figure 4.5.2-1**

### 4.5.3 CROSS-CORRELATION, THREE SOURCE PHASE NOISE MEASUREMENT

Cross-correlation of frequency sources is a relatively straightforward 4 step process –

1. measure the mixer slope(s),
2. lock the frequency sources,
3. measure the PSD using an FFT, and
4. calculate the phase noise.

#### 4.5.3.1 STEP 1: MEASURING MIXER SLOPE

When performing cross-correlation phase noise measurements, use the following procedure to determine the slope for both MIXER/LPF modules:

1. Set the AUDIO AMPLIFIER gain switch to the 0 dB position.
2. Set the PHASE LOCK CONTROL ET switch to the VAR ET position. To monitor the VAR ET voltage, switch the METER input to the PLL or PLL2 position, as appropriate.
3. On the oscilloscope, set the trigger to normal and DC couple the vertical input.
4. Adjust the VAR ET such that exactly one period ( $2\pi$  radians) of the beat note is displayed on the screen (10 divisions) with the beat note at a relatively low frequency. See Figure 4.5.3.1-1. To monitor the audible beat note, switch the SPEAKER to the PLL or PLL2 position, as appropriate, and adjust the VOLUME to desired level.
5. Adjust the oscilloscope time base to expand the view of the waveform to 1/100th that in the original view. (e.g. – change from  $T1 = 10$  msec / div to  $T2 = 0.1$  msec / div. This is a convenient change of 6 positions on a 1, 2, 5 oscilloscope).
6.  $R = [(T2 \times 10) / (T1 \times 10)] \times 2\pi$  radians =  $(1 \text{ msec} / 100 \text{ msec}) \times 2\pi$  radians =  $0.02\pi$  radians
7. The displayed portion of the waveform is now  $0.02\pi$  radians. See Figure 4.5.3.1-2.
8. Adjust the oscilloscope vertical scale and trigger level (do not adjust the vertical position) to view the partial waveform vertically within the screen at the left and right of the screen (10 divisions). See Figure 4.5.3.1-3. Measure the voltage change for this portion of the waveform ( $\Delta V = \#$  of divisions  $\times V$  / division) and calculate the slope in volts / radian using the following equation:  $Slope = \Delta V / R = \Delta V / 0.02\pi$  radians

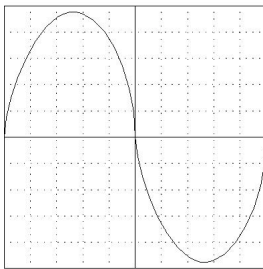

**Figure 4.5.3.1-1**

One period beat note (10 to 100 Hz)

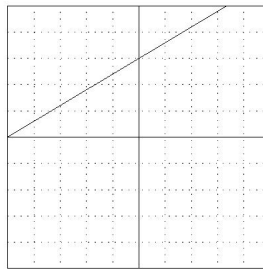

**Figure 4.5.3.1-2**

$0.02\pi$  radians beat note

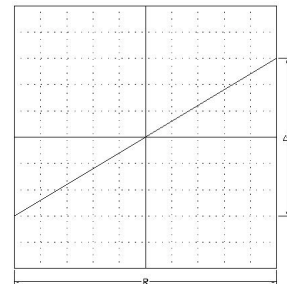

**Figure 4.5.3.1-3**

$0.02\pi$  radians vertically adjusted

#### 4.5.3.2 STEP 2: LOCK THE FREQUENCY SOURCES

When performing cross-correlation phase noise measurements, use the following procedure to lock each reference frequency source to the DUT:

1. Set the PHASE LOCK CONTROL ET switch to the PLL ET GAIN position. To monitor the PLL ET voltage, switch the METER input to PLL or PLL2 position, as appropriate. Note: The LOCK LED will be ON if one or both of the RF inputs are not present as there will be no beat note.
2. Use the PHASE LOCK CONTROL SLEW momentary switch to aid acquisition. The beat note will slow until it reaches a flat DC level as the REF frequency approaches the DUT frequency.
3. Set the AUDIO AMPLIFIER gain switch to the 30/60 dB position and the amplifier switch to the desired position (DC, AC1, etc). See note at paragraph 4.5.3.3
4. Adjust the oscilloscope trigger to auto and the time base and vertical scale (AC coupled) to settings convenient for viewing the audio noise waveform.
5. To monitor the audible noise of the circuit, switch the SPEAKER to the PLL or PLL2 position, as appropriate, and adjust the VOLUME to desired level.

#### 4.5.3.3 STEP 3: MEASURE THE PSD USING THE FFT

1. On the FFT analyzer, set the measurement mode to cross-spectrum. This will facilitate measurement of only the common phase noise at both inputs to the analyzer. Set the vertical scale to PSD in units of  $\text{dBV}_{\text{RMS}}/\sqrt{\text{Hz}}$  and frequency scale to include the desired frequency offset to be measured.
2. Measure the PSD.

Note that even with 60 dB gain, the input setting of the FFT analyzer must be adjusted low enough to view the amplified noise. Low frequency noise that may overload the amplifier of the FFT analyzer may be rolled off using the high pass filters built into the AUDIO AMPLIFIER modules. The high pass filters must be flat at the offset frequency to be measured. (Setting AC1 is flat above 10 Hz, AC2 is flat above 100 Hz, and AC3 is flat above 1000 Hz).

#### 4.5.3.4 STEP 4: CALCULATE THE ABSOLUTE PHASE NOISE

The phase noise of the DUT is determined by applying the appropriate adjustments to the measured PSD. This is accomplished by using the equation:

$$L(f)_{\text{DUT}} = [\text{PSD}] - [20\log\sqrt{(\text{slope1} \times \text{slope2})}] - [\text{amp gain}] - [\text{correction for SSB measurement}]$$

e.g.– for a circuit with slope1 determined as 0.7 V / radian and slope2 determined as 0.8 V / radian, the **AUDIO AMPLIFIER** amp select switch to **AC1**, and the **PSD** at 1000 Hz is measured as  $-96 \text{ dBV}_{\text{RMS}}/\sqrt{\text{Hz}}$ , the phase noise is calculated as

$$\begin{aligned} L(1000)_{\text{DUT}} &= -96 - 20\log\sqrt{(0.7 \times 0.8)} - 60 - 3 \\ &= -96 - 20\log(0.75) - 60 - 3 \\ &= -96 - (-2.5) - 60 - 3 \\ &= -156.5 \text{ dBc/Hz} \end{aligned}$$

### 4.6 SINGLE CHANNEL ABSOLUTE PHASE NOISE MEASUREMENT

In the event that two reference sources are not available, the phase noise of the DUT may be measured using the cross-correlation absolute phase noise measurement system configured for single channel operation with two frequency sources. The single channel phase noise measurement technique for a frequency source determines the combined absolute phase noise of the device under test (DUT) and a reference frequency source (REF) with similar or superior noise performance.

#### 4.6.1 SINGLE CHANNEL TWO SOURCE PHASE NOISE MEASUREMENT TECHNIQUE

For single channel absolute phase noise measurement, connect the DUT and REF using only the **BPMX-1000**, **BPPLL-1000**, and **BPAA-1000** modules. The DUT is connected directly to the MIXER/LPF module, omitting the high isolation reactive power splitter (see Figure 4.5.2-1).

#### 4.6.2 INITIAL CONNECTIONS [SINGLE CHANNEL]

Set up of the instrument is simple. Plug the **BPPS-1000** power supply into the back of the **BP-1000-CC**. Once that is secure, turn the units on, and if rack mounted, placed in the rack. There are no other connections or functions to be performed at the rear panels. All connections are made at the front of the instrument. Some of the connections indicated in the block diagram are internal and are so marked. To initially set up the **BP-1000-CC** unit make the following front panel connections:

To do single channel measurements on the Cross Correlator, do the connections as you would for single channel measurements (section 3.5.2.)

##### 4.6.2.1 STEP 1: MEASURING MIXER SLOPE

Follow the instructions in section 4.5.3.1

##### 4.6.2.2 STEP 2: LOCK THE FREQUENCY SOURCES

Follow the instructions in section 4.5.3.2

#### 4.6.2.3 STEP 3: MEASURE THE PSD USING THE FFT

1. On the FFT analyzer, set the measurement mode to single channel. This will facilitate measurement of the combined phase noise of the two sources. Set the vertical scale to PSD in units of  $\text{dBV}_{\text{RMS}}/\sqrt{\text{Hz}}$  and frequency scale to include the desired frequency offset to be measured.
2. Measure the PSD.

Note that even with 60 dB gain, the input setting of the FFT analyzer must be adjusted low enough to view the amplified noise. Low frequency noise that may overload the amplifier of the FFT analyzer may be rolled off using the high pass filters built into the AUDIO AMPLIFIER. The high pass filter must be flat at the offset frequency to be measured. (Setting AC1 is flat above 10 Hz, AC2 is flat above 100 Hz, and AC3 is flat above 1000 Hz).

#### 4.6.2.4 STEP 4 CALCULATE THE ABSOLUTE PHASE NOISE

1. The combined phase noise of the DUT and REF is determined by applying the appropriate adjustments to the measured PSD. This is accomplished by using the equation:

$$L(f)_{\text{COMB}} = [\text{PSD}] - [20\log(\text{slope})] - [\text{amp gain}] - [\text{correction for SSB measurement}]$$

e.g.– for a circuit with the slope determined as 0.75 V / radian, the AUDIO AMPLIFIER amp select switch to AC1, and the PSD at 1000 Hz is measured as -96  $\text{dBV}_{\text{rms}}/\sqrt{\text{Hz}}$ , the phase noise is calculated as

$$\begin{aligned} L(1000)_{\text{COMB}} &= -96 - 20\log(0.75) - 60 - 3 \\ &= -96 - (-2.5) - 60 - 3 \\ &= -156.5 \text{ dBc/Hz} \end{aligned}$$

2. To determine the noise of the DUT, the noise of a known reference source may be backed out using the following equation:

$$L(f)_{\text{DUT}} = 10\log [10(L(f)_{\text{COMB}} / 10) - 10(L(f)_{\text{REF}} / 10)]$$

NOTE: This correction is significant when the phase noise of the reference source is within 10 dB of the DUT.

e.g. –using the results from above, and assuming the phase noise of the reference source is known to be -162 dBc/Hz at 1000 Hz offset, the phase noise of the DUT is calculated as

$$\begin{aligned} L(1000)_{\text{DUT}} &= 10\log [10^{(-156.5 / 10)} - 10^{(-162 / 10)}] \\ &= 10\log [10^{-15.65} - 10^{-16.2}] \\ &= 10\log [2.239 \cdot 10^{-16} - 0.631 \cdot 10^{-16}] \\ &= 10\log [1.608 \cdot 10^{-16}] \\ &= 10 [-15.79] \\ &= -157.9 \text{ dBc/Hz} \end{aligned}$$

3. By applying the appropriate correction factor based on this equation from Table III, a quick result can be obtained.

With a known  $L(f)_{\text{REF}}$  and the combined phase noise measured  $L(f)_{\text{COMB}}$ , the difference is calculated. The associated correction factor from Table III is subtracted from the combined phase noise measured to obtain the corrected phase noise.

$$\begin{aligned} \text{e.g. –} \quad & L(f)_{\text{COMB}} - L(f)_{\text{REF}} \\ &= -162 \text{ dBc/Hz} - -156.5 \text{ dBc/Hz} \\ &= -5.5 \text{ dB} \\ & \text{rounding to -6 dB the CF is determined to be -1.3 dB} \\ & L(f)_{\text{DUT}} = -156.5 \text{ dBc/Hz} - 1.3 \text{ dB} \\ &= -157.8 \text{ dBc/Hz} \end{aligned}$$

Refer to Table III in Appendix III for correction factors.

## 5.0 OPERATION **BP-1000-RM**— RESIDUAL MEASUREMENT CONFIGURATION

The **BP-1000-RM** Residual Phase Noise Test Set consists of a two chassis configuration. The **BPMS-1000-RM** Residual Phase Noise Measurement instrument and it is powered by the **BPPS-1000** Low Noise Power Supply. The **BPMS-1000-RM** phase noise measurement system is configured to facilitate the accurate residual (additive) phase noise measurements of active or passive two-port devices such as amplifiers, multipliers, dividers, splitters, cables and filters as well as mixers.

The residual phase noise measurement requires only one frequency source. The signal from this frequency source is first reactively power split. One output of the splitter passes through the device under test (DUT), while the other output passes through a phase shifter. Two DUT's are required for devices that change the frequency (ie. multipliers, dividers, etc.) The phase shifter is adjusted to put these two signals in quadrature at the input to a mixer. The phase noise from the frequency source is coherent at the inputs to the mixer, and therefore, mostly cancelled. The remaining phase noise present at the mixer output is the residual noise from the DUT1 (and DUT2 if present). The measured voltage variations at the mixer output are easily converted to phase noise by correcting for mixer conversion and amplifier gain.

### 5.1 FRONT PANEL OVERVIEW

The **BP-1000-RM** residual phase noise measurement instrument is comprised of a mixer with low pass filters (MIXER/LPF), , AUDIO AMPLIFIER, POWER SPLITTER METER, SPEAKER, and USB controller.



Figure 5.1-1

### 5.2 REAR PANEL OVERVIEW

The DC supply input DB9 connector (Appendix III, Table I) and power switch are located on the rear panel of the instrument. All other connections used during normal operation of the unit are on the front panel.

#### **BPPS-1000**

The AC supply power entry (Appendix III, Table II) is located on the rear panel of the **BPPS-1000**. The power entry module may be configured for 115 or 230 VAC supply. The setting is indicated in the window on the module. The DC supply output D-subminiature connector (Appendix III, Table I) located on the rear panel of the unit connects to the DC supply input D-subminiature connector with the supplied cable.

### 5.3 INITIAL POWER ON

Connect the supplied DC supply interconnect cable to the **BPPS-1000** power supply and the phase noise measurement system via the 9 pin D-subminiature connectors on the rear panels. Connect the supplied power cord to the **BPPS-1000** power supply at the power entry module and to the appropriate AC voltage source. Switch the power on to both units.

**Note:** Switch the power off to the phase noise measurement system or the **BPPS-1000** power supply while configuring the test set.

### 5.4 CALIBRATION

Annual factory calibration of the AUDIO AMPLIFIER module(s) is recommended.

No periodic calibration of the remainder of the phase noise measurement system is required.

No field calibration of the **BPPS-1000** power supply is required.

## 5.5 MEASURING RESIDUAL PHASE NOISE



Figure 5.2 -1

### 5.5.1 RESIDUAL PHASE NOISE MEASUREMENT TECHNIQUE

The residual phase noise measurement technique for a device determines the combined phase noise of the device under test (DUT) and a reference frequency source (REF) with similar or superior noise performance. The MIXER/LPF module incorporates a low pass filter to block the RF frequencies to the AUDIO. The power spectral density of the output audio noise of the circuit can be measured with a signal analyzer and is easily converted to phase noise by correcting for mixer conversion and amplifier gain.

The phase slope of the MIXER/LPF may be determined by applying a known frequency modulation to the reference frequency source.

The noise output from the MIXER/LPF can be quite low, requiring amplification before signal analysis. The AUDIO AMPLIFIER exhibits intrinsic noise below  $1\text{nV}/\sqrt{\text{Hz}}$  and the MIXER/LPF exhibits similar performance with phase slopes near 1 volt/radian. Figure 5.5.2-1 below depicts a block diagram for the residual phase noise measurement configuration.

### 5.5.2 INITIAL CONNECTIONS

Set up of the instrument is simple. Plug the **BPMS-1000** power supply into the back of the **BPMS-1000-RM**. Once that is secure, you can turn the units on, and if rack mounted, placed in the rack. There are no other connections or functions to be performed at the rear panels. All connections are made at the front of the instrument. Some of the connections indicated in the block diagram are internal and are so marked. To initially set up the **BPMS-1000-RM** unit make the following front panel connections:

1. Locate the MIXER/LPF and using the short SMA terminated cable provided, connect one of the "OUT" ports to the "INPUT HIGH Z" of the Audio Amplifier.
2. Connect the "OUTPUT LOW Z" of the AMP to your measurement equipment. (FFT and Oscilloscope)
3. Connect your Reference Source to the INPUT of the Power Splitter module.
4. Connect one output of the splitter to the "RF IN" of the MIXER/LPF and the other through a phase shifting device and/or divider to the "LO IN" of the mixer. You can now take a base line measurement of the noise of the test system.
5. Disconnect the Splitter Out cable and connect it to your DUT input port. Connect the output port of the DUT to the RF IN on the instrument. When you measure the noise of the system now, you will see the noise of the test system and that of the DUT added together. Subtract the previously obtained base line and you have the resulting noise of the unit being tested. (Corrections must be applied, however.)

Notice that in the block diagram (Figure 5.5.2-2) we have introduced optional amplifiers.

The connections shown in Figures 5.5.2.-1 and 5.5.2-2 are for measuring the “noise floor” of the mixer and should be done preparatory to any sensitive measurement. The essential difference is that the device you wish to test is replaced by a cable to measure the base levels on the entire system. This cable would be replaced by the DUT during a “real” measurement.

The other line from the splitter runs through a delay line or phase shifter so that voltage measured on the oscilloscope may be varied plus and minus.

Once the noise floor of the test system is known, you replace the connecting cable with the device to be tested and re-measure the system’s noise. The difference between the two is the “residual noise” of your DUT.

***WARNING: DO NOT HOT SWAP  
Serious Damage May Result – Turn Unit Off to Change Modules.  
Failure to do so will void your warranty.***

# PHASE NOISE MEASUREMENT SYSTEM

RESIDUAL MEASUREMENT CONFIGURATION  
SYSTEM "NOISE FLOOR" MEASUREMENT

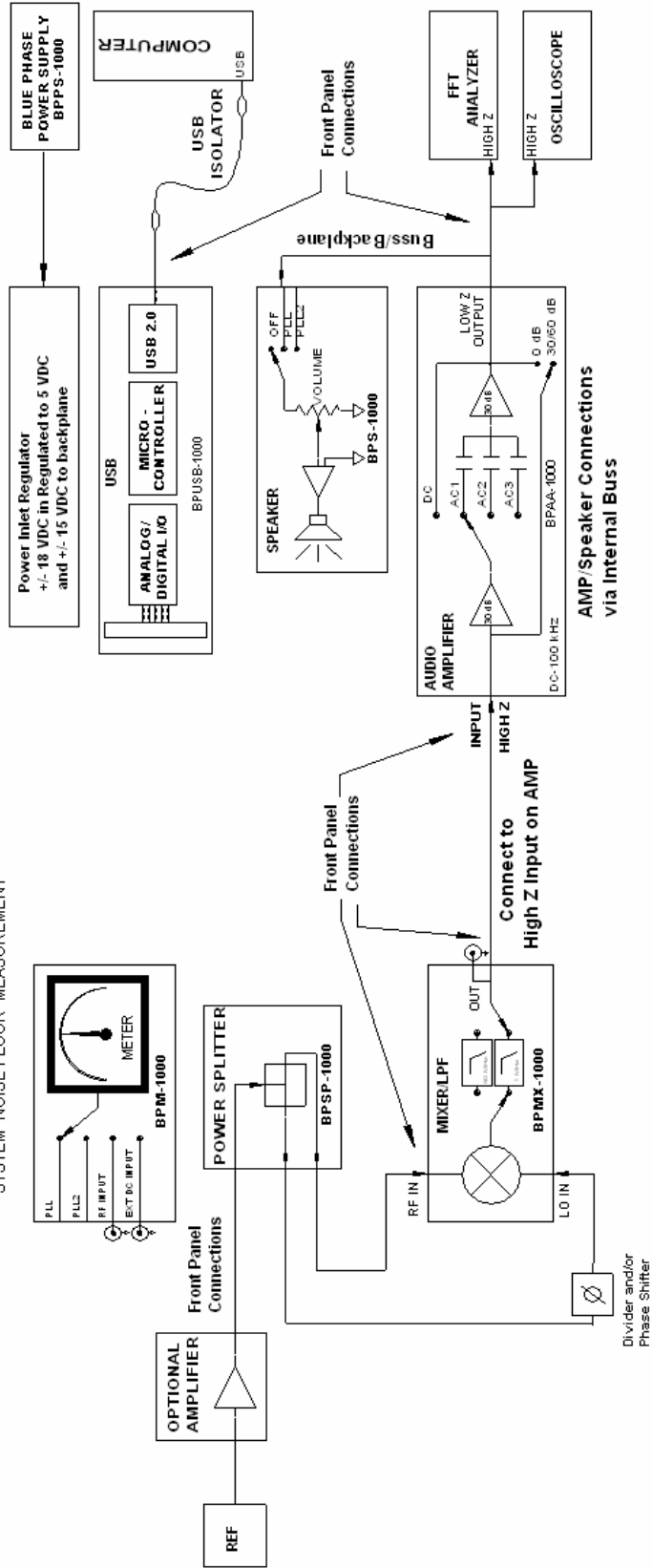

Figure 5.2-1

# PHASE NOISE MEASUREMENT SYSTEM

RESIDUAL MEASUREMENT CONFIGURATION

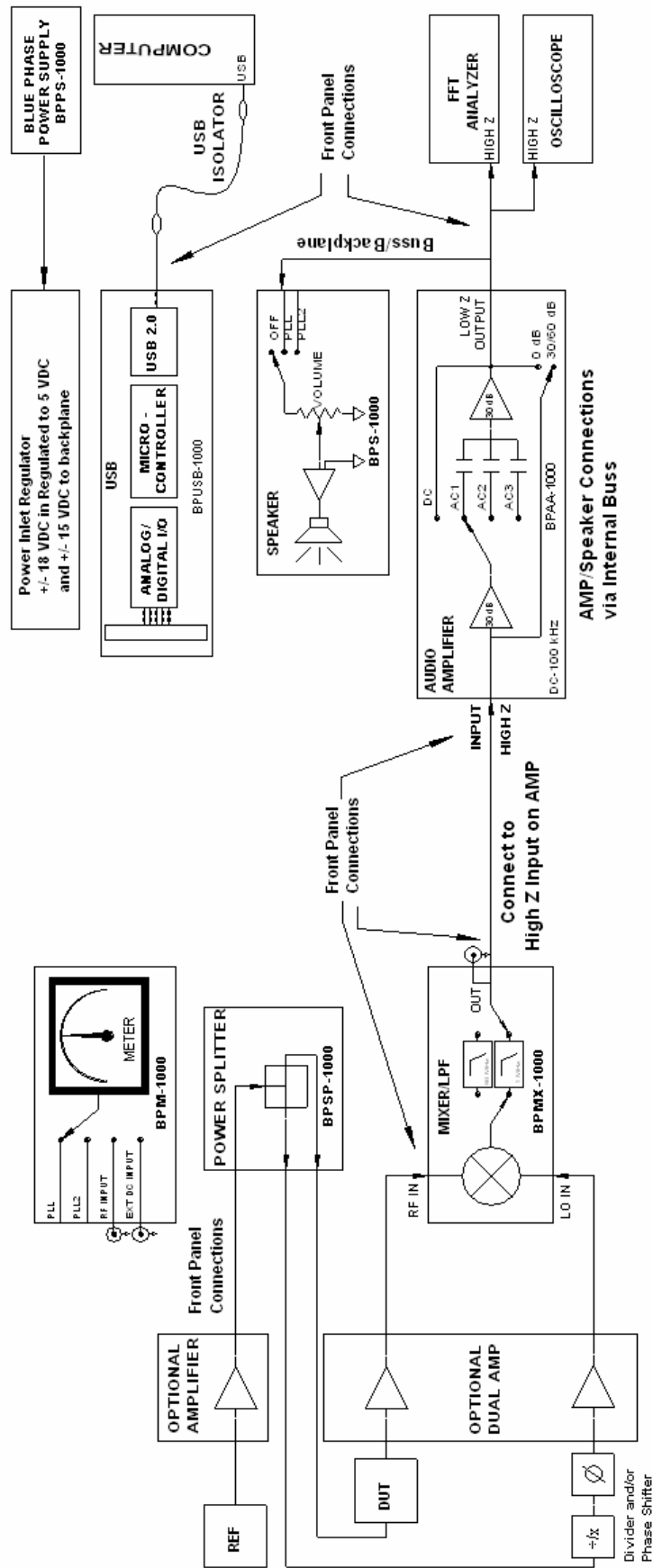

Figure 5.5.2-2

### 5.5.3 RESIDUAL PHASE NOISE MEASUREMENT

Measuring the residual phase noise of a device is a relatively straightforward 4 step process:

1. measure the mixer slope,
2. set quadrature,
3. measure the PSD using an FFT, and
4. calculate the phase noise.

#### 5.5.3.1 STEP 1: MEASURING MIXER SLOPE

1. Set the AUDIO AMPLIFIER gain switch to the 0 dB position (off).
2. On the oscilloscope, set the trigger to "Auto" and DC couple the vertical input.
3. Determine the mixer slope with the following process:

Using the delay line or phase shifter, move the delay line some amount above zero voltage, 0.2 VDC in this example and note the angle indicated on you phase shifter. The angle being measured is that number of degrees off of quadrature that produces the voltage indicated. Our example is 50.5°.

	+0.2 VDC

Figure 5.5.3.1-1

	-0.2 VDC

Figure 5.5.3.1-2

The second set of measurements is carried out in the same way. In this case move the marker to a negative 0.2 VDC and again take a reading of the angle.. Our phase shifter now indicates, for example, 64.7°

If we have used the example amounts of plus 0.2 and minus 0.2 VDC then the total change is 0.4 volts.

This is the  $\Delta V$  part of the equation which is 400 millivolts (0.4VDC).

The angle is found by taking the difference between the two measurements. In this case, the result is 14.2 degrees apparent.

You may have to correct for phase shifter calibration at 16hz and your measurement is at 400 MHz,  $14.2^\circ \cdot .4 = 5.68^\circ$

	+0.2 VDC
0.0 VDC	
	-0.2 VDC

Figure 5.5.3.1-3

The angle measured is now converted to radians.  $5.68^\circ = .099 \text{ rad}$ .

The value of degrees is multiplied by 2 times  $\pi$  and divided by  $360^\circ$ . This result is the number of radians at maximum slope.

$$\text{Radians} = [\text{Angle} \times 2(\pi)/360^\circ]$$

And

$$\text{Slope} = \Delta V / R = .4 \text{ VDC} / .099 \text{ radians} = 4.03 \text{ V/rad}$$

### 5.5.3.2 STEP 2: SET QUADRATURE

1. Adjust the oscilloscope and test apparatus so as to get 0 Vdc as shown in Figure 5.5.3.1-3.
2. Set the AUDIO AMPLIFIER gain switch to the 30 / 60 dB position and the amplifier switch to the desired position (DC, AC1, etc). See note at paragraph 5.5.3.3.
3. Adjust the oscilloscope trigger to auto and the time base and vertical scale (AC coupled) to settings convenient for viewing the audio noise waveform.
4. To monitor the audible noise of the circuit, switch the SPEAKER to the PLL position and adjust the VOLUME to desired level.

### 5.5.3.3 STEP 3: MEASURE THE PSD USING THE FFT

1. On the FFT analyzer, set the vertical scale to PSD in units of dBVrms /  $\sqrt{\text{Hz}}$  and frequency scale to include the desired frequency offset to be measured.
2. Measure the PSD.

Note that even with 60 dB gain, the input setting of the FFT analyzer must be adjusted low enough to view the amplified noise. Low frequency noise that may overload the amplifier of FFT analyzer may be rolled off using the high pass filters built into the AUDIO AMPLIFIER. The high pass filter must be flat at the offset frequency to be measured. (Setting AC1 is flat above 10 Hz, AC2 is flat above 100 Hz, and AC3 is flat above 1000 Hz).

### 5.5.3.4 STEP 4: CALCULATE THE RESIDUAL PHASE NOISE.

The combined phase noise of the DUT and System is determined by applying the appropriate adjustments to the measured PSD. This is accomplished by using the equation:

$$L(f)_{\text{COMB}} = [\text{PSD}] - [20\log(\text{slope})] - [\text{amp gain}] - [\text{corr. for SSB meas.}]$$

e.g.– for a circuit with the slope determined as 0.75 V / radian, the AUDIO AMPLIFIER amp select switch to AC1, and the PSD at 1000 Hz is measured as -96 dBV<sub>RMS</sub>/ $\sqrt{\text{Hz}}$ , the phase noise is calculated as

$$\begin{aligned} L(1000)_{\text{COMB}} &= -96 - 20\log(0.75) - 60 - 3 \\ &= -96 - (-2.5) - 60 - 3 \\ &= -156.5 \text{ dBc/Hz} \end{aligned}$$

Refer to Table III in Appendix III for correction factors.

NOTE: Measurements of actual devices follow the same procedures as for the “floor” and in the case of having a device in the line from splitter to LO IN instead of a simple cable.

Please visit <http://www.wenzel.com/documents/spread.htm> for phase noise spreadsheets and other tools.

## Appendix I

**WARNING: DO NOT HOT SWAP**  
**Serious Damage May Result – Turn Unit Off to Change Modules.**  
*Failure to do so will void your warranty.*

### 6.0 BASE MODULE DESCRIPTIONS

#### 6.1 MIXER/LPF – BPMX-1000

The low noise mixer / low pass filter module (MIXER/LPF) mixes two RF input frequencies –a reference signal and a DUT source signal. Two **BLUE TOPS™** low pass filters are incorporated at the output of the mixer to block the RF frequencies at the output of the MIXER/LPF module. By selecting LPF LOW, the MIXER/LPF module attenuates frequencies above 1 MHz. By selecting LPF HIGH, the MIXER/LPF module attenuates frequencies above 50 MHz.

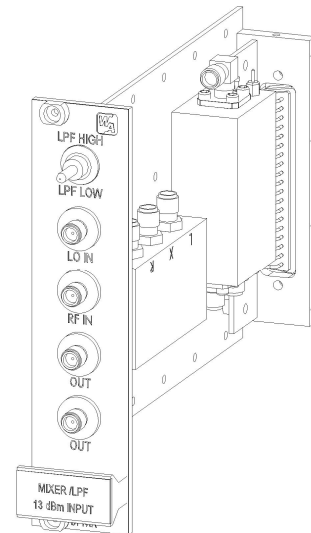

#### 6.2 PHASE LOCK CONTROL – BPPLL-1000

The PLL IN of the low noise PHASE LOCK CONTROL module (PLL) accepts the audio signal from the MIXER/LPF OUT and is normalized to DC. This resultant DC phase error voltage is fed back via the PLL ET OUT to the reference oscillator (REF) electrical tuning input and integrates until the DUT source and reference frequencies are held at quadrature. With the ET switch in the VAR ET position, the operator controls the DC voltage at the PLL ET OUT. With the ET switch in the PLL ET GAIN position, the operator controls the DC voltage gain at the PLL ET OUT. The PLL SLEW allows the operator to cause DC voltage at the PLL ET OUT vary in the positive or negative direction. A phase locked condition is signified when the LOCK indicator LED is on.

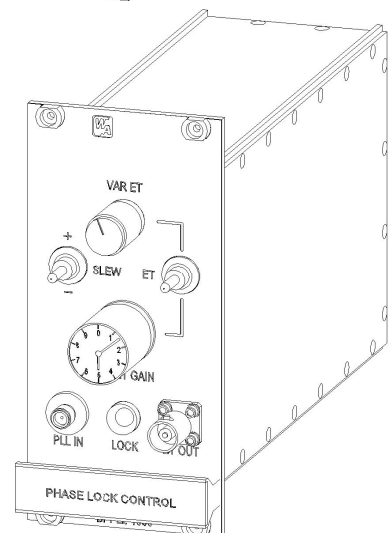

#### 6.3 AUDIO AMPLIFIER – BPAA-1000

The AUDIO AMPLIFIER module exhibits intrinsic noise below 1 nV /  $\sqrt{\text{Hz}}$ . The AUDIO AMPLIFIER accepts the audio signal from the MIXER/LPF OUT and provides 0, 30, or 60 dB of gain\* for signal analysis. High pass filters built into the AUDIO AMPLIFIER roll off low frequency noise that may overload the amplifier of the FFT analyzer. The high pass filter is selected via the HPF switch to maintain a flat response at the offset frequency to be measured.

HPF Switch Settings:

DC	No filter	30 dB gain
AC1	Flat above 10 Hz	60 dB gain
AC2	Flat above 100 Hz	60 dB gain
AC3	Flat above 1000 Hz	60 dB gain

0 dB gain is selected using the gain switch when measuring phase slope

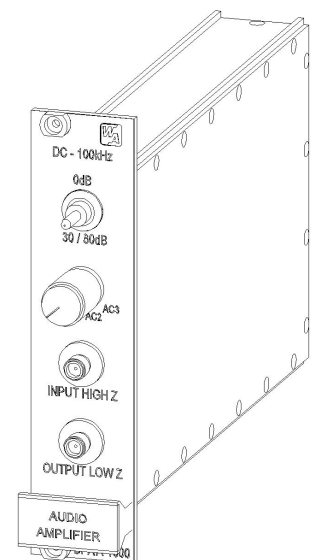

#### 6.4 METER – BPM-1000

The METER module can be used for reference monitoring of four possible signals.

SWITCH SETTING	METER DISPLAY
PLL	PHASE LOCK CONTROL ET OUT*
PLL2	PHASE LOCK CONTROL 2 ET OUT*
RF INPUT	RF level (dBm)
EXT INPUT	DC voltage at EXTERNAL INPUT port

\* the internal loop amplifier voltage or the variable electrical tuning voltage (VAR ET), as selected with the ET switch

Note: The METER module is intended as a testing aid which provides relatively coarse measurements. Readings acquired should be considered for reference only. It is not calibrated and should not be used for critical measurements.

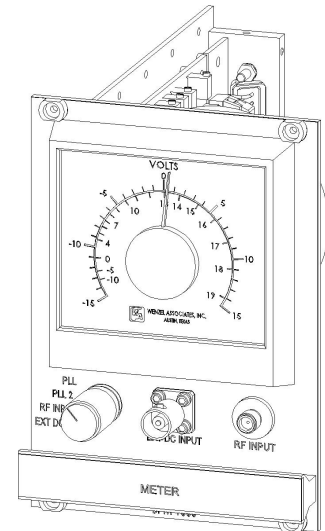

#### 6.5 SPEAKER – BPS-1000

The SPEAKER module allows for audible monitoring of the audio output beat note or noise. The PLL select switch and volume adjustment provide for control of the speaker output to operator preference.

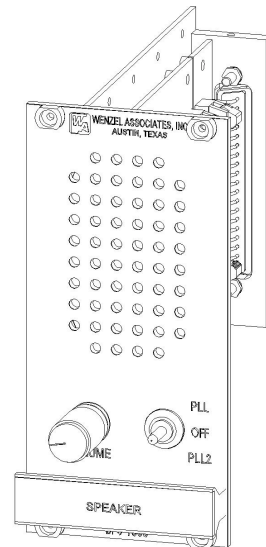

#### 6.6 VARIABLE VOLTAGE – BPVV-1000

The VARIABLE VOLTAGE module provides a voltage source for fixed tuning of the DUT. This voltage is intended for use to adjust the center frequency so that the DUT may be phase locked for testing. The VAR OUT output is limited to 40 ma maximum supply current.

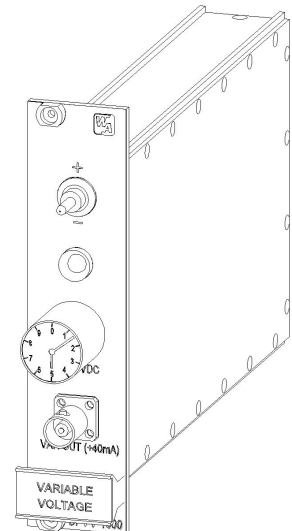

## 6.7 USB CONTROLLER – **BPUSB-1000**

The USB CONTROLLER module provides the digital communications link to the phase noise measurement system. Digital I/O communications with the are facilitated through the USB port on the front of the instrument.

Digital communications are accomplished with the incorporation of a third party USB-based analog and digital I/O device, part number PMD-1208FS, manufactured by Measurement Computing Corporation. Refer to the PMD-1208FS documentation and software for detailed information on this interface. The PMD-1208FS is configured in the 8-channel single-ended mode. Table III details the connector pin out and function specifications.

The Ulinx USB Extender – Isolator, Model UEF10M is used to isolate switching power supply ground noise of the computer from the phase noise measurement system.

USB control software, developed using LabView, is available online for the **BLUEPHASE 1000** as an open source project. Multiple configurations of test software will be made available as they are developed.

Please visit the support area at <http://www.wenzel.com> for current availability of phase noise measurement and other software.

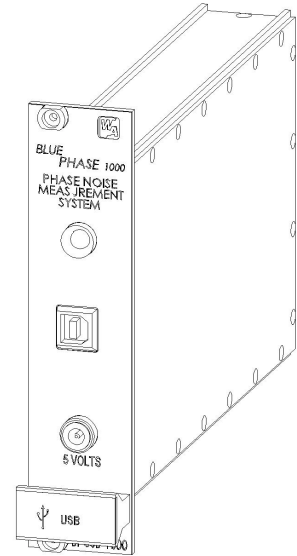

USB INTERFACE				
PMD Terminal	Signal Name	Function	State	P1 Pin (DB-37)
1	CH0 IN	PLL1 ET		20
2	CH1 IN	PLL2 ET		21
3	AGND	GND		22
4	CH2 IN			—
5	CH3 IN			—
6	AGND	GND		25
7	CH4 IN	PLL1 LOCK		26
8	CH5 IN	PLL2 LOCK		27
9	AGND	GND		28
10	CH6 IN	AMP1 OUTPUT		29
11	CH7 IN	AMP2 OUTPUT		30
12	AGND	GND		31
13	D/A OUT 0	PLL1 USB VAR ET		32
14	D/A OUT 1	PLL2 USB VAR ET		33
15	AGND			—
16	CAL			—
17	GND			—
18	TRIG IN			—
19	SYNC			—
20	CTR			—
21	PORT A0	PLL1 HPF SEL 0 (LSB)	See Table III-I	1
22	PORT A1	PLL1 HPF SEL 1 (MSB)	See Table III-I	2
23	PORT A2	PLL1 GAIN SELECT	LOW = 0 dB, HIGH (see Table III-I)	3
24	PORT A3	PLL2 GAIN SELECT	LOW = 0 dB, HIGH (see Table III-I)	4
25	PORT A4	PLL2 HPF SEL 0 (LSB)	See Table III-I	5
26	PORT A5	PLL2 HPF SEL 1 (MSB)	See Table III-I	6
27	PORT A6	PLL2 ET SELECT	LOW = PLL ET, HIGH = VAR ET	7
28	PORT A7	PLL2 SLEW	LOW (OFF), HIGH (ON)	8
29	GND			—
30	PC +5V			—
31	GND			—
32	PORT B0	LOCAL / REMOTE	LOW = LOCAL, HIGH = REMOTE	9
33	PORT B1	PLL1 ET SELECT	LOW = PLL ET, HIGH = VAR ET	10
34	PORT B2	SLEW DIRECTION	LOW (-), HIGH (+)	11
35	PORT B3	PLL1 SLEW	LOW (OFF), HIGH (ON)	12
36	PORT B4	PLL CAP SEL A	LOW = DESELECT, HIGH = SELECT	13
37	PORT B5	PLL CAP SEL B	LOW = DESELECT, HIGH = SELECT	14
38	PORT B6	PLL CAP SEL C	LOW = DESELECT, HIGH = SELECT	15
39	PORT B7	PLL CAP SEL D	LOW = DESELECT, HIGH = SELECT	16
40	GND	GND		37

HPF SELECT				
HFP SEL 0	LOW	HIGH	LOW	HIGH
HPF SEL 1	LOW	LOW	HIGH	HIGH
HPF SELECTED	AC1	AC2	AC3	DC
FLAT ABOVE	10 Hz	100 Hz	1000 Hz	DC
AMP GAIN *	60 dB	60 dB	60 dB	30 dB
* with GAIN SELECT set HIGH				

## Appendix II

**WARNING: DO NOT HOT SWAP**  
**Serious Damage May Result – Turn Unit Off to Change Modules.**  
*Failure to do so will void your warranty.*

### 7.0 STANDARD CONFIGURATIONS

#### 7.1 **BP-1000-SC** – SINGLE CHANNEL ABSOLUTE MEASUREMENT SYSTEM

The Single Channel system includes the **BPMS-1000-SC** instrument and the **BPPS-1000** power supply with the following modules standard.

BPUSB-1000	USB Controller
BPS-1000	Speaker
BPAA-1000	Audio Amplifier
BPMX-1000	Mixer, LPF, 5 to 1500 MHz, +13 dBm
BPPLL-1000	Phase Lock Control
BPVV-1000	Variable Voltage Source
BPM-1000	Meter



**BP-1000-SC**

#### 7.2 **BP-1000-CC** – CROSS-CORRELATION ABSOLUTE MEASUREMENT SYSTEM

The Cross Correlation system includes the **BPMS-1000-CC** instrument and the **BPPS-1000** power supply with the following modules standard.

BPUSB-1000	USB Controller
BPS-1000	Speaker
BPAA-1000	Audio Amplifier
BPMX-1000	Mixer/LPF, 5 to 1500 MHz, +13 dBm
BPPLL-1000	Phase Lock Control
BPAA-1000-C	Audio Amplifier 2 [for Cross- correlation]
BPMX-1000-C	Mixer/LPF 2, 5 to 1500 MHz, +13 dBm [for Cross- correlation]
BPPLL-1000-C	Phase Lock Control 2 [for Cross-correlation]
BPM-1000	Meter



**BP-1000-CC**

#### 7.3 **BP-1000-RM** – RESIDUAL MEASUREMENT SYSTEM

The Residual Measurement system includes the **BPMS-1000-RM** instrument and the **BPPS-1000** power supply with the following modules standard.

BPUSB-1000	USB Controller
BPS-1000	Speaker
BPAA-1000	Audio Amplifier
BPMX-1000	Mixer, Low Pass Filter
BPSP-1000	Power Splitter, 2-1200 MHz
BPM-1000	Meter



**BP-1000-RM**

## Appendix III

**WARNING: DO NOT HOT SWAP**  
**Serious Damage May Result – Turn Unit Off to Change Modules.**  
**Failure to do so will void your warranty.**

### 8.0 ADDITIONAL MODULES - *BLUEPHASE 1000*

BPAA-1020	Audio Amplifier, Extended Range, 20 MHz max.
BPDBA-xxxx	Dual Broadband Amplifier, RF, Custom
BPMX-1010	Mixer/LPF, 5 to 1500 MHz, +10 dBm
BPMX-1020	Mixer/LPF, 2 to 4 GHz, +13 dBm
BPMX-1030	Mixer/LPF, 4 to 12 GHz, +10 dBm
BPMX-1040	Mixer/LPF, 1 to 26.5 GHz, +10 dBm
BPMXM-0005	Mixer, High Slope, Active Buffered Inputs, 5 MHz, +13 dBm
BPMXM-0010	Mixer, High Slope, Active Buffered Inputs, 10 MHz, +13 dBm
BPMXM-0050	Mixer, High Slope, Active Buffered Inputs, 50 MHz, +13 dBm
BPMXM-0080	Mixer, High Slope, Active Buffered Inputs, 80 MHz, +13 dBm
BPMXM-0100	Mixer, High Slope, Active Buffered Inputs, 100 MHz, +13 dBm
BPMXM-0125	Mixer, High Slope, Active Buffered Inputs, 125 MHz, +13 dBm
BPMXM-xxxx	Mixer, High Slope, Active Buffered Inputs, Custom
BPVR-1505-PP	Voltage Regulator, +15 VDC / +5 VDC, 1A max.
BPVR-1515-PP	Voltage Regulator, Dual +15 VDC, 1A max.
BPVR-1505-PN	Voltage Regulator, +15 VDC / -5 VDC, 1A max.
BPVR-1505-NN	Voltage Regulator, -15 VDC / -5 VDC, 1A max.
BPVR-1515-NN	Voltage Regulator, Dual -15 VDC, 1A max.
BPVR-_____	Voltage Regulator, Custom Output Voltages

Please visit <http://www.wenzel.com> for up to date availability of additional modules for the *BLUEPHASE 1000*

## 9.0 REAR PANEL CONNECTIONS

TABLE I. DC POWER SUPPLY INTERFACE CONNECTIONS			
BPPS-1000 DC OUTPUT CONNECTOR		BLUEPHASE 1000 DC INPUT CONNECTOR	
Pin	Function	Pin	Function
1	+18 VDC OUT	1	+18 VDC IN
2	n/c	2	n/c
3	n/c	3	n/c
4	n/c	4	n/c
5	-18 VDC OUT	5	-18 VDC IN
6	+18 VDC Return (chassis ground)	6	+18 VDC Return (chassis ground)
7	n/c	7	n/c
8	n/c	8	n/c
9	-18 VDC Return (chassis ground)	9	-18 VDC Return (chassis ground)

TABLE II. AC POWER SUPPLY CONNECTIONS	
BPPS-1000 AC INPUT CONNECTOR	
Connection	Pin
Line (115/230 VAC, 50/60 Hz)	L
Ground (case)	G
Neutral	N

## 10.0 CORRECTION FACTOR TABLE

TABLE III	
$L(f)_{\text{COMB}} - L(f)_{\text{REF}}$	Correction Factor
-3 dB	-3.0 dB
-4 dB	-2.2 dB
-5 dB	-1.7 dB
-6 dB	-1.3 dB
-7 dB	-1.0 dB
-8 dB	-0.7 dB
-9 dB	-0.6 dB
-10 dB	-0.5 dB