



Crystal Oscillators > Phase Locked & Auto Switching >

Features:

- Very Low Noise Outputs from 5 to 30 MHz
- Loop Bandwidth Chosen for Application
- Designed for Vibration Isolators
- -170 Phase Noise Floors

Applications:

- Radar Systems
- Coherent Sources
- Physics Applications
- Test Equipment

The HF Phase Locked Oscillators provide a variety of input and output options, ensuring optimal phase noise during locked and unlocked conditions. The HF PLO is based on a very low noise SC-cut crystal oscillator. Noise floors are typically -170 dBc/Hz. Inputs can be specified from 1 MHz to 30 MHz. Also, the input frequency may be specified at the same frequency as the output frequency. Unusual divider ratios must be reviewed by the sales department.

Typical Specifications:

Frequency (Specify)		5 to 10 MHz	
Frequency		5	10
Input Level		10 Mhz 7 dBm ±5	
Output Level		+13	
Aging		±5 x 10 ⁻⁹ / day, typical	
Phase Noise	10 Hz	-145	-130
	100 Hz	-165	-158
	1 kHz	-170	-170
	10 kHz	-172	-172
Temperature Stability (Specify)		±1 x 10 ⁻⁸ to ±2 x 10 ⁻⁷	
Range A	0 to +50C		
Range B	0 to +65C		
Range C	0 to +70C		
Range D	-20 to +70C		
Range E	-40 to +70C		
Spurious		-70	
Harmonics		-30	
Loop Bandwidth,		<1 Hz, target	
Supply Voltage (Specify)		+12 or +15	
Warm-up Power		8 at start-up for 5 minutes at 25°C	
Total Power typical		5 at steady state +25°C	
Crystal Type		SC	
Dimensions		63.5 x 88.9 x 20.32 2.5 x 3.5 x 0.8	
Connectors		SMAs and solder pins on side	

HF PLO Series

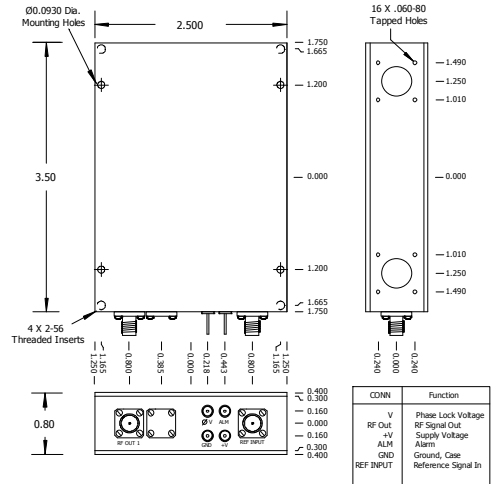

VHF Locked to HF

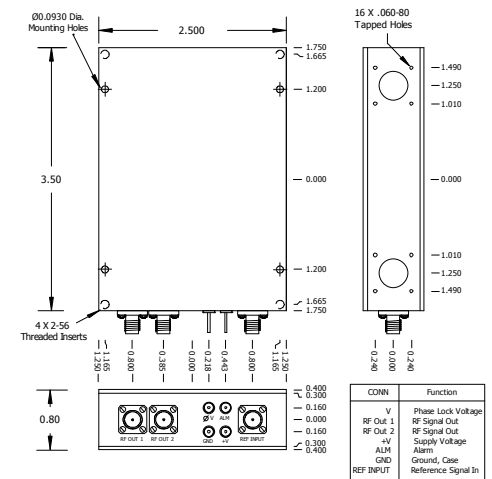

VHF Locked to VHF