

REV	DATE	REVISION RECORD	DWN	AUTH
-	03-20-95	Draft	BH	
A	11-12-96	Package	BH	
B	02-17-99	Package Description	MS	

**OUTPUT**

**Frequency**

5 MHz

**Level**

+13 ±2dBm into 50 ohms

**STABILITY**

**Aging**

1 x 10<sup>-9</sup> per day  
after 30 days operating, typical

**Phase Noise L(f)**

10 Hz -130 dBc  
100 Hz -155 dBc  
1 KHz -165 dBc  
10 KHz -165 dBc

**Temperature Stability**

±1.5 x 10<sup>-8</sup>, 0° to +50°C (Ref +25°C)

**MECHANICAL**

**Dimensions**

2 x 2 x 1"

**Connectors**

SMA and feedthru capacitors

**Packaging**

Solder sealed steel can

**POWER REQUIREMENTS**

**Warm-Up Power**

<5 Watts for 5 minutes

**Total Power**

<2.2 Watts at +25°C

**Supply Voltage**

+15 VDC

**ADJUSTMENT**

**Mechanical Tuning**

±1 x 10<sup>-6</sup>

**Electrical Tuning**

±2 x 10<sup>-7</sup>, ±5 VDC  
Negative slope

**CRYSTAL**

**Type**

5 MHz SC-cut

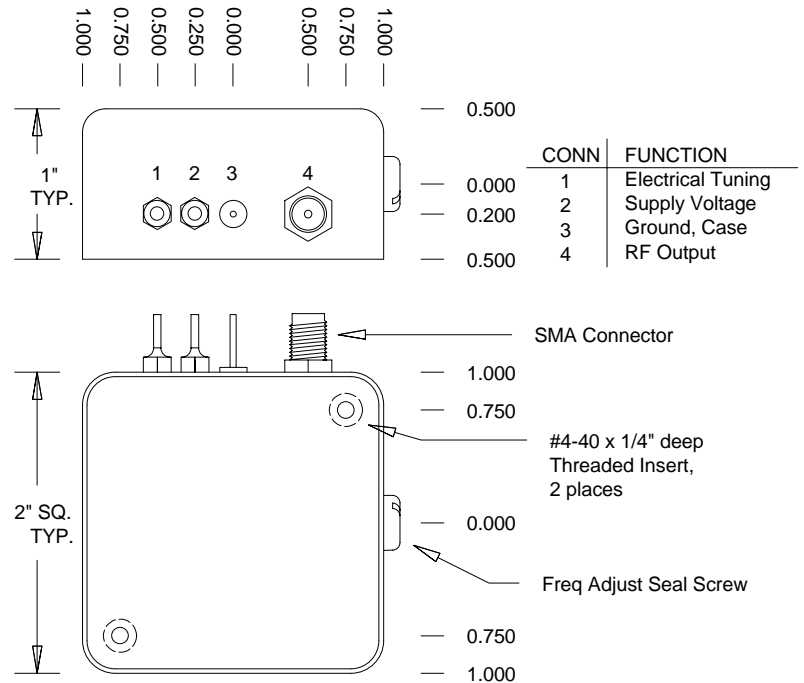

Connector numbers are for reference only, they are not marked on unit.



**Wenzel Associates, Inc.**

Austin, Texas

Title:

**Standard 5 MHz-SC Streamline Crystal Oscillator**

P/N: <b>501-04604</b>	Rev: <b>B</b>	Date: <b>02-17-99</b>	Drawn:	Ref:
--------------------------	------------------	--------------------------	--------	------

Tolerances: (except as noted) Dimensions are in inches	0.XX Dec: <b>±0.030"</b>	0.XXX Dec: <b>±0.010"</b>	FSCM: <b>62821</b>	Page 1 of 1
--	-----------------------------	------------------------------	-----------------------	-------------