

REV	DATE	REVISION RECORD	DWN	AUTH
-	03-20-95	Draft	BH	
A	04-07-98	Revise Can	KW	BK
B	08-16-00	Phase Noise	BH	

OUTPUT

Frequency

10 MHz

Level

+13 dBm ±2dBm into 50 ohms

STABILITY

Aging

1 x 10⁻⁹ per day
after 30 days operating, typical

Phase Noise L(f)

10 Hz -115 dBc
100 Hz -145 dBc
1 KHz -165 dBc
10 KHz -165 dBc

Temperature Stability

±2 x 10⁻⁸, 0° to +50°C (Ref +25°C)

MECHANICAL

Dimensions

2 x 2 x 1"

Connectors

SMA and feedthru capacitor

Packaging

Solder sealed steel can

POWER REQUIREMENTS

Warm-Up Power

<5 Watts for 5 minutes

Total Power

<2.2 Watts at +25°C

Supply Voltage

+15 VDC

ADJUSTMENT

Mechanical Tuning

±4 x 10⁻⁶

Electrical Tuning

±2 x 10⁻⁷, ±5 VDC
Negative slope

CRYSTAL

Type

10 MHz AT-cut

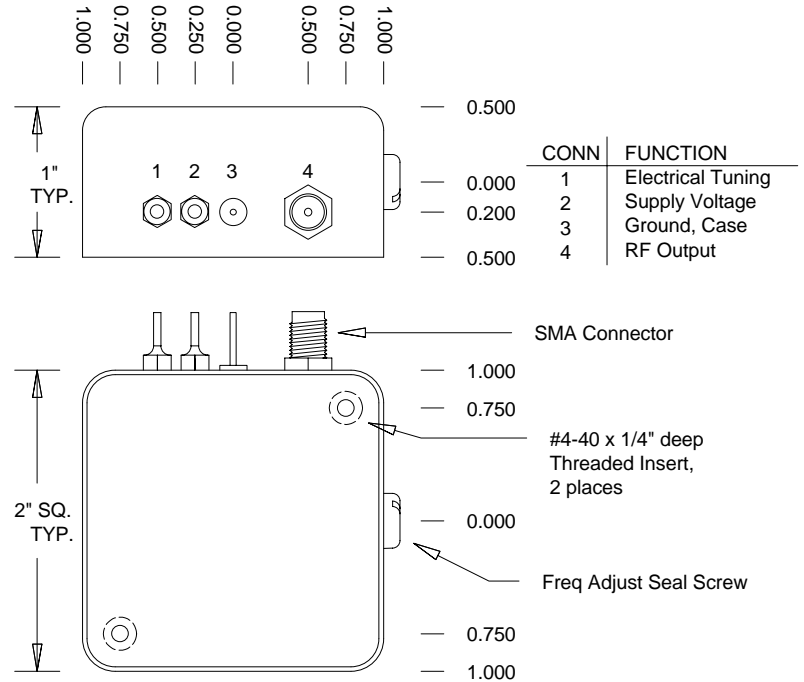

Connector numbers are for reference only, they are not marked on unit.



Wenzel Associates, Inc.

Austin, Texas

Title:

Premium 10 MHz-AT Streamline Crystal Oscillator

P/N: 501-04607	Rev: B	Date: 08-16-00	Drawn:	Ref:
--------------------------	------------------	--------------------------	--------	------

Tolerances: (except as noted) Dimensions are in inches	0.XX Dec: ±0.030"	0.XXX Dec: ±0.010"	FSCM: 62821	Page 1 of 1
--	-----------------------------	------------------------------	-----------------------	-------------